

CUESTIONARIO PARA LA SELECCION DE TRANSPORTADORES DE BANDA Questionary for Belt Conveyor selection

NUMERO DE OFERTA: _____
Offer No.:

CLIENTE: Customer		N° PEDIDO: Order N°	
DIRECCION: Address		TELEFONO: Telephone	
PROVINCIA: Country	C.P.:	FAX: Fax	
PERSONA DE CONTACTO: Contact Person		FECHA: Date	E-MAIL:

PRODUCTO A TRANSPORTAR Product to transport

DIMENSIONES (LxAxH) Dimensions	
PESO UNITARIO (Kg) Single weight	
MATERIAL Material	
TEMPERATURA (°C) Temperature	
ARISTAS Sharp Edges	
IMPREGNACION (Líquidos/Aceites) Impregnate (Liquid/Oil)	
POLVO o FRAGMENTOS Dust/Fragments	
ACUMULACION Accumulation	
OTROS Other	

OPCIONES Options

APOYOS Supports		CANTIDAD Quantity	
GUIAS Guides		TIPO Type	
VARIADOR DE FRECUENCIA Frequency Converter			
PERFILES Cleats			
TIPO Type	ALTO Height	ANCHO Width	PASO Step
CAJA ELECTRICA (Con protección térmica) Switch box with thermal protection			
OTROS / Others			

DATOS DEL TRANSPORTADOR Conveyor Dimensions

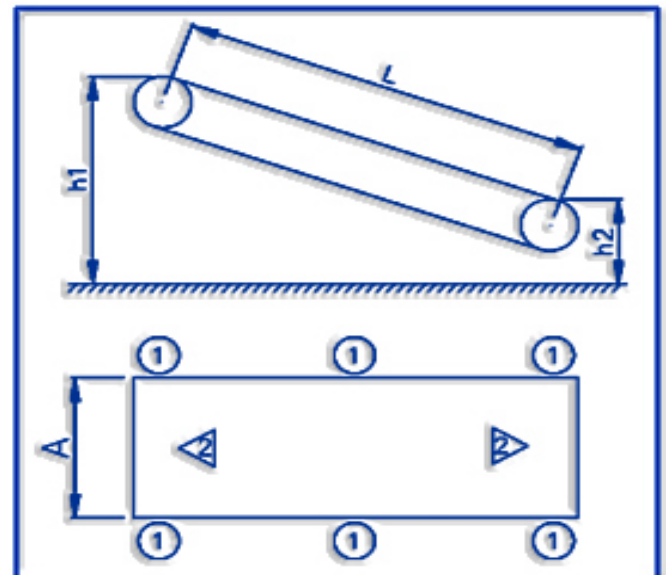

Notas / Notes

TIPO Type		
TENSION Voltage		V
CARGA TOTAL Payload		Kg
L		mm
h1		mm
h2		mm
A		mm
V		m/min
POSICIÓN MOTOR Motor Position	SENTIDO MOTOR Motor Direction	
Arranques / Paros On / Off		Veces / Hora Times / Hour

